

**TRUE** TRUE EUROPE  
 Field's End Road, Goldthorpe, Nr. Rotherham, South Yorkshire S63 9EU,  
 England • www.truemfg.com • Tel 01709 888 080 • FAX 01709 880 838  
 • Free Phone 0 800 783 2049 • Free Phone to U.S. 0 800 894 928

Project Name: \_\_\_\_\_ A/A # \_\_\_\_\_  
 Location: \_\_\_\_\_  
 Item #: \_\_\_\_\_ Qty: \_\_\_\_\_ SIS # \_\_\_\_\_  
 Model #: \_\_\_\_\_

Model:  
**TGU-3**

**Gastronorm Undercounter:**  
*Solid Door Refrigerator*



**TGU-3**

- ▶ True's undercounter units are designed with enduring quality that protects your long term investment.
- ▶ Designed using the highest quality materials and components to provide the user with colder product temperatures, lower utility costs, exceptional food safety and the best value in today's food service marketplace.
- ▶ Oversized, environmentally friendly (134A) forced-air refrigeration system holds .5°C to 3.3°C (33°F to 38°F).
- ▶ 300 series stainless steel exterior.
- ▶ Radius countertop.
- ▶ 300 series stainless steel interior.
- ▶ LED temperature display.
- ▶ Front breathing.
- ▶ Foamed-in-place, high density polyurethane insulation (CFC free).
- ▶ 3 sets of 1/1 gastronorm rails with stainless steel shelves per section.

**ADVANCED TECHNOLOGY**  
**Reverse Condensing Fan Motor**



Reversing  
 Air Flow  
 Keeps Your  
 Condenser  
 Clean!

**Radius  
 Countertop**



**ROUGH-IN DATA**

Specifications subject to change without notice.

Chart dimensions rounded up to the next whole millimeter (inches rounded up to the next 1/8").

Model	Doors	Capacity (liters) (Cu. Ft.)	Shelves	Cabinet Dimensions (mm) (inches)			HP	Voltage	Amps	NEMA Config.	Cord Length (total m) (total ft.)	Crated Weight (kg) (lbs.)
				L	D†	H*						
TGU-3	3	456 16.1	9	1880 74	712 28	737 29	1/3	230-240/50/1	3.0	▲	2.74 9	200 440

† Depth does not include 26 mm (1") for bumpers.

\* Height does not include 127 mm (5") for castors.

▲ Plug type varies by country.



APPROVALS:

AVAILABLE AT:

12/05

Printed in U.S.A.

Model:  
**TGU-3**

## Gastronorm Undercounter: Solid Door Refrigerator



### STANDARD FEATURES

#### DESIGN

- True's commitment to using the highest quality materials and oversized refrigeration systems provides the user with colder product temperatures, lower utility costs, exceptional food safety and the best value in today's food service marketplace.

#### REFRIGERATION SYSTEM

- Factory engineered self-contained, capillary tube system using environmentally friendly (CFC free) 134A refrigerant.
- Oversized, factory balanced refrigeration system with guided airflow to provide uniform product temperature.
- Extra large evaporator coil balanced with higher horsepower compressor and large condenser; maintains cabinet temperatures of .5°C to 3.3°C (33°F to 38°F) for the best in food preservation.
- Sealed, cast iron, self-lubricating evaporator fan motors and larger fan blades give True undercounter units a more efficient low velocity, high volume airflow design. This unique design insures faster temperature recovery and shorter run times in the busiest of food service environments.

#### CABINET CONSTRUCTION

- Exterior - 300 series stainless steel.
- Interior - 300 series stainless steel.
- Countertop - heavy 16 gauge stainless radius front.
- Insulation - entire cabinet structure and solid doors are foamed-in-place using high density, CFC free, polyurethane insulation.
- 102 mm (4") diameter stem castors - locks provided on front set. 864 mm (34") work surface height.

#### DOORS

- Stainless steel.
- Positive seal self-closing doors with 90° stay open feature. Doors swing within cabinet dimensions.
- Each door fitted with 305 mm (12") long recessed handle that are foamed-in-place with a sheet is interlock to insure permanent attachment.
- Magnetic door gaskets of one piece construction, removable without tools for ease of cleaning.

#### SHELVING

- Three (3) sets of 1/1 gastronorm rails per section.
- Three (3) stainless steel shelves 324 mm L x 534 mm D (12<sup>3</sup>/<sub>4</sub>" x 21") per section.

#### MODEL FEATURES

- Evaporator is epoxy coated to eliminate the potential of corrosion.
- Self-contained condensate pan. No need for external drain.

#### ELECTRICAL

- Unit completely pre-wired at factory and ready for final connection to a 230-240/50/1 phase dedicated outlet. Cord and plug set included.
- Plug type varies by country.

#### OPTIONAL FEATURES/ACCESSORIES

- 64 mm (2<sup>1</sup>/<sub>2</sub>") diameter castors.
- 153 mm (6") standard legs (requires leg mounting plates).
- 153 mm (6") seismic/flanged legs (requires leg mounting plates).

### PLAN VIEW

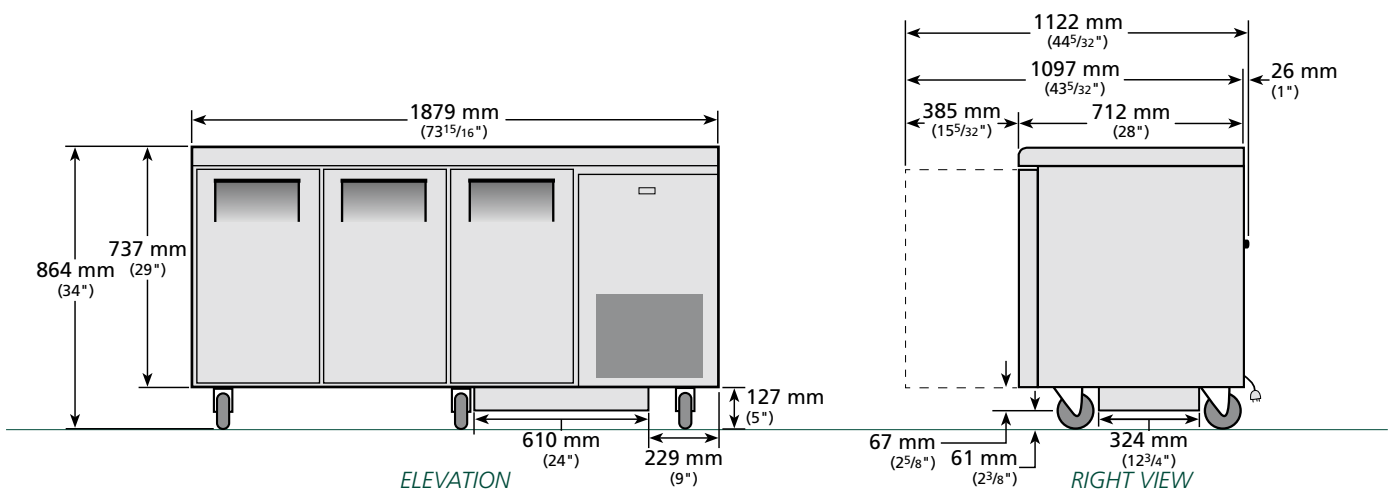

METRIC DIMENSIONS ROUNDED UP TO THE NEAREST WHOLE MILLIMETER

SPECIFICATIONS SUBJECT TO CHANGE WITHOUT NOTICE



Model	Elevation	Right	Plan	3D
TGU-3				

**TRUE EUROPE**