



Field's End Road, Goldthorpe, Nr. Rotherham, South Yorkshire S63 9EU, England • www.truemfg.com • Tel 01709 888 080 • FAX 01709 880 838  
• Free Phone 0 800 783 2049 • Free Phone to U.S. 0 800 894 928

Project Name: _____	AIA # _____
Location: _____	SIS # _____
Item #: _____ Qty: _____	
Model #: _____	

Model:  
**T-19E**

**T Series:**  
*Reach-In Solid Door Refrigerator*



**T-19E**

- ▶ True's solid door reach-in's are designed with enduring quality that protects your long term investment.
  - ▶ Designed using the highest quality materials and components to provide the user with colder product temperatures, lower utility costs, exceptional food safety and the best value in today's food service marketplace.
  - ▶ Oversized, factory balanced, refrigeration system holds .5°C to 3.3°C (33°F to 38°F) for the best in food preservation.
  - ▶ 300 series stainless steel solid doors and front. The finest stainless available; higher tensile strength for fewer dents and scratches.
  - ▶ Adjustable, heavy duty PVC coated shelves.
  - ▶ Positive seal self-closing door. Lifetime guaranteed door hinges and torsion type closure system.
- Bottom mounted units feature:**
- ▶ "No stoop" lower shelf.
  - ▶ Storage on top of cabinet.
  - ▶ Compressor performs in coolest, most grease free area of kitchen.
  - ▶ Easily accessible condenser coil for cleaning.

**ROUGH-IN DATA**

Specifications subject to change without notice.  
Chart dimensions rounded up to the next whole millimeter (inches rounded up to the next 1/8").

Model	Doors	Capacity (liters) (Cu. Ft.)	Shelves	Cabinet Dimensions (mm) (inches)			HP	Voltage	Amps	NEMA Config.	Cord Length (total m) (total ft.)	Crated Weight (kg) (lbs.)
				L	D	H						
T-19E	1	538 19	4	686 27	623 24 1/2	1995 78 1/2	1/4	230-240/50/1	2.4	▲	2.74 8	108 240

▲ Plug type varies by country.

 USA 6/07	 Printed in U.S.A.	<b>APPROVALS:</b>	<b>AVAILABLE AT:</b>

Model:  
**T-19E**

**T Series:**  
Reach-In Solid Door Refrigerator



## STANDARD FEATURES

### DESIGN

- True's commitment to using the highest quality materials and oversized refrigeration systems provides the user with colder product temperatures, lower utility costs, exceptional food safety and the best value in today's food service marketplace.

### REFRIGERATION SYSTEM

- Factory engineered, self-contained, capillary tube system using environmentally friendly (CFC free) 134A refrigerant.
- Extra large evaporator coil balanced with higher horsepower compressor and large condenser; maintains .5°C to 3.3°C (33°F to 38°F) for the best in food preservation.
- Sealed, cast iron, self-lubricating evaporator fan motor(s) and larger fan blades give True reach-in's a more efficient low velocity, high volume airflow design. This unique design ensures faster temperature recovery and shorter run times in the busiest of food service environments.
- Bottom mounted condensing unit positioned for easy maintenance. Compressor runs in coolest and most grease free area of the kitchen. Allows for storage area on top of unit.

### CABINET CONSTRUCTION

- Exterior - 300 series stainless steel front grill and shroud. Anodized quality aluminum exterior ends, back and top.

- Interior - attractive white aluminum liner. 300 series stainless floor with coved corners.
- Insulation - entire cabinet structure and solid door are foamed-in-place using high density, CFC free, polyurethane insulation.
- Welded, heavy duty galvanized frame rail dipped in rust inhibiting enamel paint for corrosion protection inside and out.
- Frame rail fitted with 64 mm (2<sup>1</sup>/<sub>2</sub>" ) diameter stem castors - locks provided on front set.

### DOOR

- 300 series stainless steel exterior with white aluminum liner to match cabinet interior. Door extends full width of cabinet shell. Door lock standard.
- Lifetime guaranteed recessed door handle. Door fitted with 305 mm (12") long recessed handle that is foamed-in-place with a sheet metal interlock to ensure permanent attachment.
- Positive seal self-closing door. Lifetime guaranteed door hinges and torsion type closure system.
- Magnetic door gasket of one piece construction, removable without tools for ease of cleaning.

### SHELVING

- Four (4) adjustable, heavy duty PVC coated wire shelves 574 mm x 464 mm (22<sup>9</sup>/<sub>16</sub>" L x 18<sup>1</sup>/<sub>4</sub>" D). Four (4) chrome plated shelf clips included per shelf.

- Shelf support pilasters made of same material as cabinet interior; shelves are adjustable on 13 mm (1/2") increments.

### LIGHTING

- Incandescent interior lighting - safety shielded. Lights activated by rocker switch mounted above door.

### MODEL FEATURES

- Exterior temperature display.
- Evaporator is epoxy coated to eliminate the potential of corrosion.

### ELECTRICAL

- Unit completely pre-wired at factory and ready for final connection to a 230-240/50/1 phase dedicated outlet. Cord and plug set included.
- Plug type varies by country.

### OPTIONAL FEATURES/ACCESSORIES

Upcharge and lead times may apply.

- 153 mm (6") standard legs.
- 153 mm (6") seismic/flanged legs.
- Additional shelves.
- Remote cabinets (condensing unit supplied by others; system comes standard with 404A expansion valve and requires R404A refrigerant). Consult factory technical service department for BTU information.

## PLAN VIEW

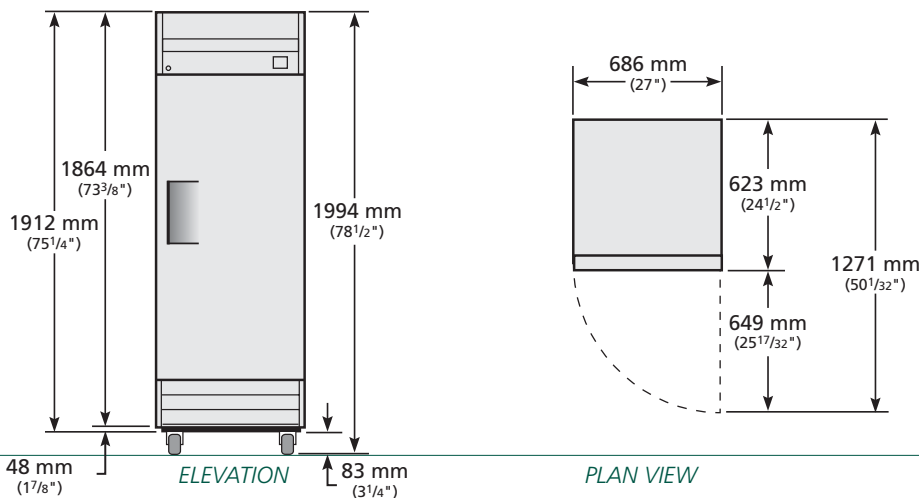

METRIC DIMENSIONS ROUNDED UP TO THE NEAREST WHOLE MILLIMETER

SPECIFICATIONS SUBJECT TO CHANGE WITHOUT NOTICE



Model	Elevation	Right	Plan	3D
T-19E				

**TRUE EUROPE**